

◆ DESCRIPTION

The MT2576 series are monolithic integrated circuits that provide a step-down switching regulator, and capable of driving a 3A load with excellent line and load regulations.

These devices are available in fixed output voltage of 3.3V, 5V,12V, and adjustable output version. Requiring a minimum number of external components, these regulators are simple to use and include internal frequency compensation and a fixed-frequency oscillator. The MT2576 operates at a switching frequency of 52 KHz thus allowing smaller sized filter components than what would be needed with lower frequency switching regulators.

The device features include a guaranteed $\pm 4\%$ tolerance on output voltage under specified input voltage and output load conditions, and $\pm 10\%$ on the oscillator frequency. It does also provide external shutdown, current limited and over temperature shutdown functions for complete protection under fault conditions.

◆ FEATURES

- Guaranteed 3A output current
- 3.3V, 5V, 12V and adjustable output versions
- Thermal shutdown and current limit protection
- Internal oscillator of 52kHz fixed frequency.
- TO-220 , TO-263 and SO-8 packages available
- Wide adjust version output voltage range, from 1.23V to 37V $\pm 4\%$ max. at over line and load conditions.

◆ APPLICATIONS

- ADD-ON-Cards switching regulators
- Simple high efficiency step-down(buck) regulator
- LCD Monitors

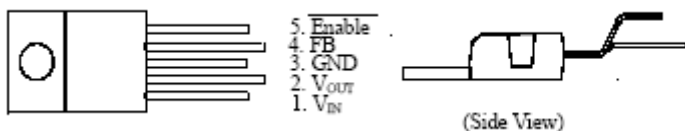
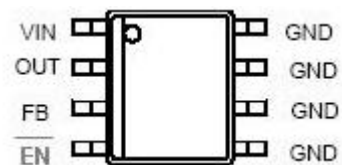
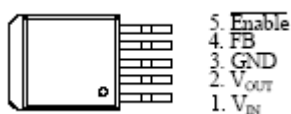
◆ PIN CONFIGURATIONS

MT2576-X.XC

MT2576-X.XM(P)

MT2576-X.XD

MT2576-X.XK

◆ ABSOLUTE MAXIMUM RATINGS

Parameter	Symbol	Maximum	Unit
Input supply voltage	V_{IN}	45	V
Thermal resistance junction to ambient TO-220(K) TO-220(C) TO-263(D)	θ_{JA}	45	$^{\circ}\text{C}/\text{W}$
Operating junction temperature	T_J	150	$^{\circ}\text{C}$
Storage temperature range	T_{STG}	- 65 to 150	$^{\circ}\text{C}$
Lead temperature (soldering) 10sec	T_{LEAD}	260	$^{\circ}\text{C}$

Note : Exceeding these ratings could cause damage to the device. All voltages are with respect to Ground. Currents are positive into, negative out of the specified terminal.

◆ ORDERING INFORMATION

Device	Package		Vout Volts	T_A ($^{\circ}\text{C}$)
MT2576-X.XK	K	TO-220	X.X_ 3.3/ 5.0/ 12/ ADJ	0-70
MT2576-X.XC	C	TO-220		
MT2576-X.XD	D	TO-263		
MT2576-X.XM	M	SO-8		
MT2576-X.XP	P*	PSOP-8		

* With thermal PAD (PSOP)

◆ POWER DISSIPATION TABLE

Package	θ_{JA} ($^{\circ}\text{C}/\text{W}$)	$T_A \leq 25^{\circ}\text{C}$ Power rating(mW)	$T_A = 70^{\circ}\text{C}$ Power rating(mW)	$T_A = 85^{\circ}\text{C}$ Power rating (mW)
K	45	2775	1776	1443
C	45	2775	1776	1443
D	45	2775	1776	1443
M	70	1786	1143	929

Note :

- Exceeding the maximum allowable power dissipation will result in excessive die temperature, and the regulator will go into Thermal shutdown.
- T_J : Junction Temperature Calculation: $T_J = T_A + (P_D \times \theta_{JA})$
The θ_{JA} numbers are guidelines for the thermal performance of the device/PC-board system. All of the above assume no Ambient airflow.
- θ_{JA} : Thermal Resistance-Junction to Ambient, D_F : Derating factor, P_D : Power consumption

◆ RECOMMENDED OPERATING CONDITIONS

Parameter	Symbol	Operating Conditions			Unit
		Min.	Typ.	Max.	
Input Voltage	V_{IN}	-	-	40	V
Junction temperature Range	T_J	-40 $\leq T_J \leq$ 125			$^{\circ}\text{C}$

3A 52KHz Step-Down DC/DC Converter
◆ ELECTRICAL CHARACTERISTICS
 $T_J=25^{\circ}\text{C}$, $V_{IN}=12\text{V}$ for 3.3V, 5V and Adjustable version, $I_{LOAD} = 0.5\text{A}$, unless otherwise specified

Parameter		Symbol	Conditions		Min.	Typ.	Max.	Unit
Output Voltage (Note 1)	MT2576-3.3	V_{OUT}	Typical Applications OF Figure 1		3.234	3.300	3.366	V
	MT2576-5.0				4.900	5.000	5.100	V
Output Voltage (Note 1)	MT2576-3.3	V_{OUT}	0.5A \leq I _{LOAD} \leq 3A Typical Applications of Figure1	6V \leq V _{IN} \leq 40V	3.168	3.300	3.432	V
	MT2576-5.0			8V \leq V _{IN} \leq 40V	4.800	5.000	5.200	V
Output Voltage (Note 1)	MT2576-3.3	V_{OUT}	0.5A \leq I _{LOAD} \leq 3A -40 $^{\circ}$ C \leq T _J \leq 125 $^{\circ}$ C Typical Applications of Figure1	6V \leq V _{IN} \leq 40V	3.135	3.300	3.482	V
	MT2576-5.0			8V \leq V _{IN} \leq 40V	4.750	5.000	5.250	V
Feedback Voltage (Note1)	MT2576-ADJ	V_{OUTFB}	Typical Applications of Figure2	$V_{OUT}=5\text{V}$	1.217	1.230	1.243	V
Feedback Voltage (Note1)	MT2576-ADJ	V_{OUTFB}	8V \leq V _{IN} \leq 40V, $V_{OUT}=5\text{V}$ Typical Applications of Figure2	0.5A \leq I _{LOAD} \leq 3A	1.193	1.230	1.267	V
Feedback Voltage (Note1)	MT2576-ADJ	V_{OUTFB}	8V \leq V _{IN} \leq 40V, $V_{OUT}=5\text{V}$, Typical Applications of Figure2	0.5A \leq I _{LOAD} \leq 3A -40 $^{\circ}$ C \leq T _J \leq 125 $^{\circ}$ C	1.180	1.230	1.286	V
Efficiency	MT2576-3.3		I _{LOAD} =3A		-	75	-	%
	MT2576-5.0				-	77	-	
	MT2576-ADJ			I _{LOAD} =3A, $V_{OUT}=5\text{V}$	-	77	-	
Feedback bias Current		I_{FB}	$V_{OUT}=5\text{V}$ (Adjustable Only)	T _J =25 $^{\circ}$ C	-	50	100	nA
				-40 $^{\circ}$ C \leq T _J \leq 125 $^{\circ}$ C	-	-	500	
Oscillator Frequency (Note2)		F_{OSC}		T _J =25 $^{\circ}$ C	47	52	58	KHz
				-40 $^{\circ}$ C < T _J < 125 $^{\circ}$ C	42	52	63	
Saturation Voltage		V_{SAT}	I _o = 3A, (Note4)	T _J =25 $^{\circ}$ C	-	1.4	1.8	V
				-40 $^{\circ}$ C \leq T _J \leq 125 $^{\circ}$ C	-	-	2.0	
Max. Duty Cycle (ON)			(Note5)		93	98	-	%
Min. Duty Cycle (OFF)			$V_{FB} = 12\text{V}$ force driver off		-	0	-	%
Current Limit		I_{LIMIT}	(Note 2.4)	T _J =25 $^{\circ}$ C	4.2	5.8	6.9	A
				-40 $^{\circ}$ C \leq T _J \leq 125 $^{\circ}$ C	3.5	5.8	7.5	
Output Leakage Current		I_{LEAK}	(Note 3)	$V_{OUT}=0\text{V}$	-	-	2	mA
				$V_{OUT}=-1\text{V}$	-	7.5	30	
Quiescent Current		I_Q	(Note3)		-	5	10	mA
Standby Current		I_{STBY}	ENABLE Pin=5V, (OFF)		-	50	200	μA

◆ ELECTRICAL CHARACTERISTICS
 $T_J=25^{\circ}\text{C}$, $V_{IN}=12\text{V}$ for 3.3V, 5V and Adjustable version, $I_{LOAD} = 0.5\text{A}$, unless otherwise specified

ENABLE Pin Logic Input Threshold Voltage	V_{IH}	$V_{OUT}=0\text{V}$	2.2	1.4	-	V
	V_{IL}	$V_{OUT}=\text{Nominal Output Voltage}$	-	1.2	1.0	
ENABLE Pin Logic Input Current	I_{IH}	ENABLE pin=5V(OFF)	-	12	30	μA
	I_{IL}	ENABLE pin=0V(ON)	-	0	10	

NOTES:

Note 1: External components such as the catch diode, inductor, input and output capacitors can affect switching regulator system performance. Refer to Application Information for details.

Note 2: The oscillator frequency reduces to approximately 11kHz in the event of fault conditions, such as output short or overload. And the regulated output voltage will drop approximately 40% from the nominal output voltage. This self-protection feature lowers the average power dissipation by lowering the minimum duty cycle from 5% down to approximately 2%.

Note 3: For these parameters, FB is removed from V_{OUT} and connected to +12V for the Adjustable, 3.3V and 5V Versions to force the output transistor OFF.

Note 4: V_{OUT} pin sourcing current. No diode, inductor or capacitor connect to V_{OUT}.

Note 5: F_B is removed from V_{OUT} and connected to 0V.

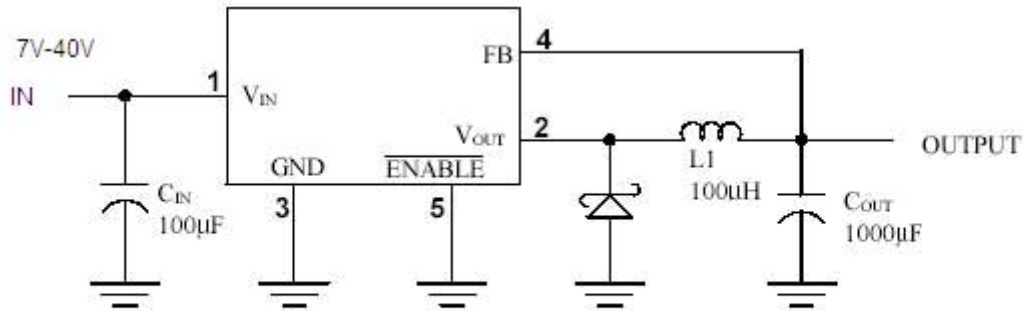
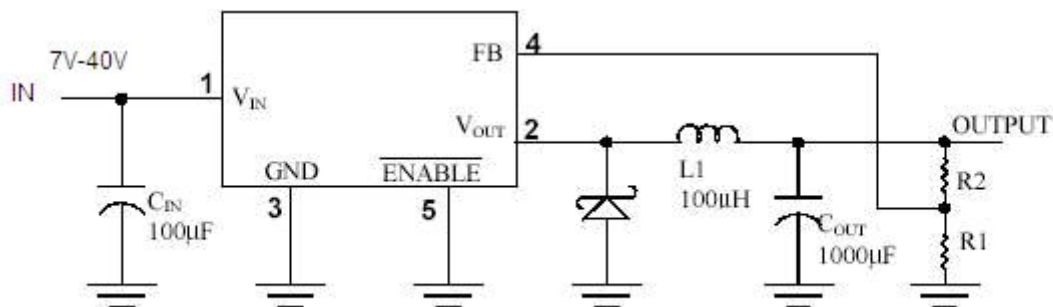
◆ TYPICAL APPLICATIONS
Fixed Output Voltage Version:

Figure 1. Fixed Output Voltage Versions
Adjustable Voltage Version:

Figure 2. Adjustable Output Voltage Versions

$$V_{OUT} = V_{REF} \left(1 + \frac{R2}{R1} \right)$$

$$R2 = R1 \left(\frac{V_{OUT}}{V_{REF}} - 1 \right)$$

 Where $V_{REF} = 1.23V$, $R1$ between 1K and 5K

◆ APPLICATION NOTE**Maximum Power Dissipation Calculation:**

$$P_{D(max)} = [(V_{IN(max)} - V_{O(nom)})] \times I_{O(nom)} + V_{IN(max)} \times I_Q$$

Where: $V_{O(nom)}$: The nominal output voltage

$I_{O(nom)}$: The nominal output current, and

I_Q : The quiescent current the regulator consumes at $I_{O(MAX)}$

$V_{IN(max)}$: The maximum input voltage

◆ Application Information**Input Capacitors (CIN)**

It is required that V_{IN} must be bypassed with at least a 100 μ F electrolytic capacitor for stability. Also, it is strongly recommended the capacitor's leads must be kept short, and located near the regulator as possible.

For low operating temperature range, for example, below -25°C, the input capacitor value may need to be larger. This is due to the reason that the capacitance value of electrolytic capacitors decreases and the ESR increases with lower temperatures and age. Paralleling a ceramic or solid tantalum capacitor will increase the regulator stability at cold temperatures.

Output Capacitors (COUT)

An output capacitor is also required to filter the output voltage and is needed for loop stability. The capacitor should be located near the MT2576 using short PC board traces. Low ESR types capacitors are recommended for low output ripple voltage and good stability. Generally, low value or low voltage (less than 12V) electrolytic capacitors usually have higher ESR numbers. For example, the lower capacitor values (220 μ F–1000 μ F) will yield typically 50 mV to 150 mV of output ripple voltage, while larger-value capacitors will reduce the ripple to approximately 20 mV to 50 mV.

The amount of output ripple voltage is primarily a function of the ESR (Equivalent Series Resistance) of the output capacitor and the amplitude of the inductor ripple current (ΔI_{IND}).

$$\text{Output Ripple Voltage} = (\Delta I_{IND}) \times (\text{ESR of } C_{OUT})$$

Some capacitors called “high-frequency,” “low-inductance,” or “low-ESR.” are recommended to use to further reduce the output ripple voltage to 10 mV or 20 mV. However, very low ESR capacitors, such as Tantalum capacitors, should be carefully evaluated.

Catch Diode

This diode is required to provide a return path for the inductor current when the switch is off. It should be located close to the MT2576 using short leads and short printed circuit traces as possible.

To satisfy the need of fast switching speed and low forward voltage drop, Schottky diodes are widely used to provide the best efficiency, especially in low output voltage switching regulators (less than 5V). Besides, fast-Recovery, high-efficiency, or ultra-fast recovery diodes are also suitable. But some types with an abrupt turn-off characteristic may cause instability and EMI problems. A fast-recovery diode with soft recovery characteristics is a better choice.

Output Voltage Ripple and Transients

The output ripple voltage is due mainly to the inductor sawtooth ripple current multiplied by the ESR of the output capacitor.

The output voltage of a switching power supply will contain a sawtooth ripple voltage at the switcher frequency, typically about 1% of the output voltage, and may also contain short voltage spikes at the peaks of the sawtooth waveform.

Due to the fast switching action, and the parasitic inductance of the output filter capacitor, there is voltage spikes presenting at the peaks of the sawtooth waveform. Cautions must be taken for stray capacitance, wiring inductance, and even the scope probes used for transients evaluation. To minimize these voltage spikes, shortening the lead length and PCB traces is always the first thought. Further more, an additional small LC filter (20 μ H & 100 μ F) (as shown in Figure 3) will possibly provide a 10X reduction in output ripple voltage and transients.

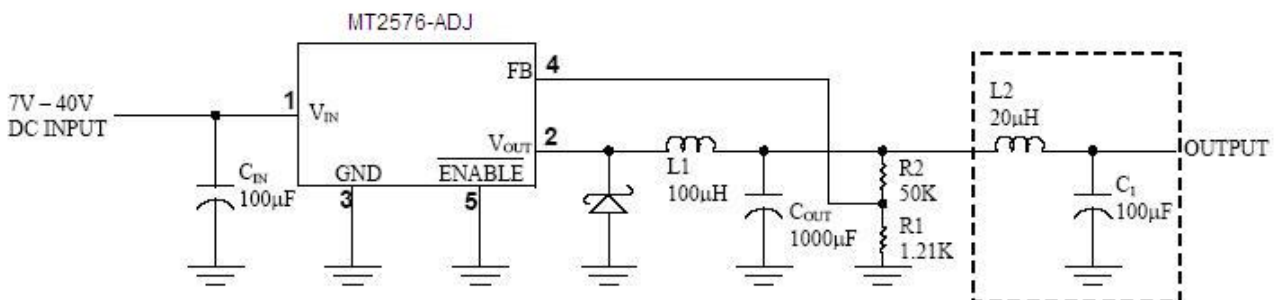

Figure 3. LC Filter for Low Output Ripple

Inductor Selection

The MT2576 can be used for either continuous or discontinuous modes of operation. Each mode has distinctively different operating characteristics, which can affect the regulator performance and requirements.

With relatively heavy load currents, the circuit operates in the continuous mode (inductor current always flowing), but under light load conditions, the circuit will be forced to the discontinuous mode (inductor current falls to zero for a period of time). For light loads (less than approximately 300 mA) it may be desirable to operate the regulator in the discontinuous mode, primarily because of the lower inductor values required for the discontinuous mode.

Inductors are available in different styles such as pot core, toroid, E-frame, bobbin core, et., as well as different core materials, such as ferrites and powdered iron. The least expensive, the bobbin core type, consists of wire wrapped on a ferrite rod core. This type of construction makes for an inexpensive inductor, but since the magnetic flux is not completely contained within the core, it generates more electromagnetic interference (EMI). This EMI can cause problems in sensitive circuits, or can give incorrect scope readings because of induced voltages in the scope probe.

An inductor should not be operated beyond its maximum rated current because it may saturate. When an inductor begins to saturate, the inductance decreases rapidly and the inductor begins to look mainly resistive (the DC resistance of the winding). This will cause the switch current to rise very rapidly. Different inductor types have different saturation characteristics, and this should be well considered when selecting an inductor.

Feedback Connection

For fixed output voltage version, the FB (feedback) pin must be connected to VOUT. For the adjustable version, it is important to place the output voltage ratio resistors near MT2576 as possible in order to minimize the noise introduction.

ENABLE

It is required that the ENABLE must not be left open. For normal operation, connect this pin to a “LOW” voltage (typically, below 1.6V). On the other hand, for standby mode, connect this pin with a “HIGH” voltage. This pin can be safely pulled up to $+V_{IN}$ without a resistor in series with it.

Grounding

To maintain output voltage stability, the power ground connections must be low-impedance. For the 5-lead TO-220 and TO-263 style package, both the tab and pin 3 are ground and either connection may be used.

Heat Sink and Thermal Consideration

Although the MT2576 requires only a small heat sink for most cases, the following thermal consideration is important for all operation. With the package thermal resistances θ_{JA} and θ_{JC} , total power dissipation can be estimated as follows:

$$P_D = (V_{IN} \times I_Q) + (V_{OUT} / V_{IN}) (I_{LOAD} \times V_{SAT})$$

When no heat sink is used, the junction temperature rise can be determined by the following:

$$\Delta T_J = P_D \times \theta_{JA}$$

With the ambient temperature, the actual junction temperature will be:

$$T_J = \Delta T_J + T_A$$

If the actual operating junction temperature is out of the safe operating junction temperature (typically 125°C), then a heat sink is required. When using a heat sink, the junction temperature rise will be reduced by the following:

$$\Delta T_J = P_D \times (\theta_{JC} + \theta_{interface} + \theta_{Heat\ sink})$$

As one can see from the above, it is important to choose a heat sink with adequate size and thermal resistance, such that to maintain the regulator's junction temperature below the maximum operating temperature.

◆ TYPICAL PERFORMANCE CHARACTERISTICS

Test circuits of Figure 1 and 2, $T_J=25^\circ\text{C}$, unless otherwise specified.

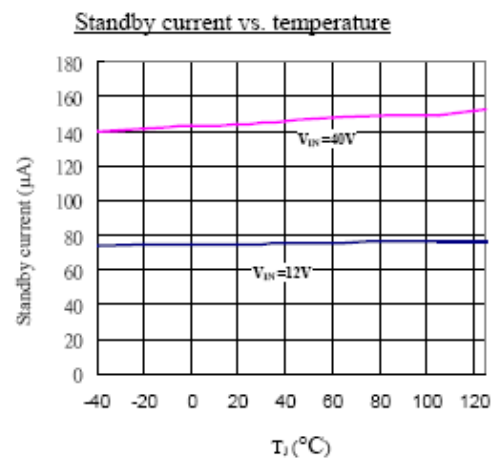
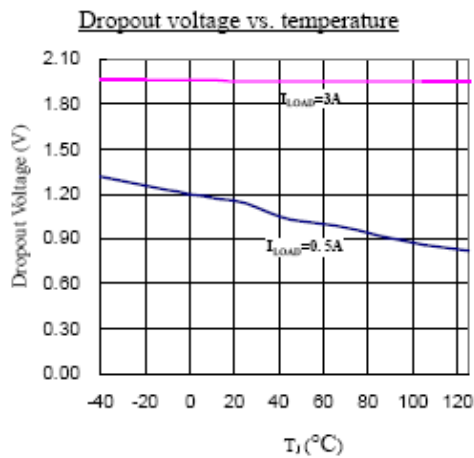
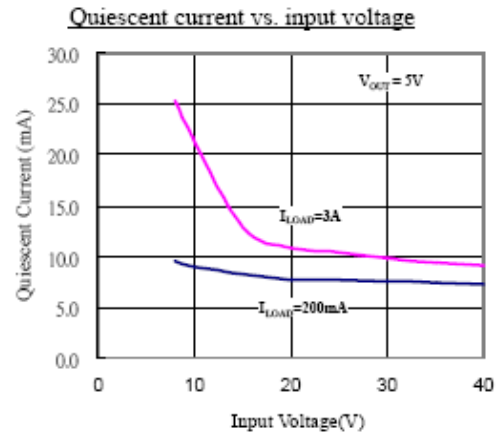
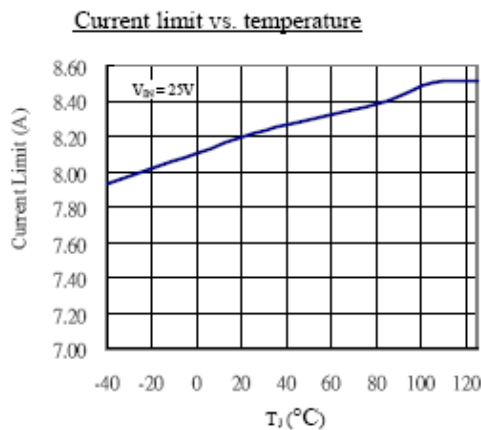
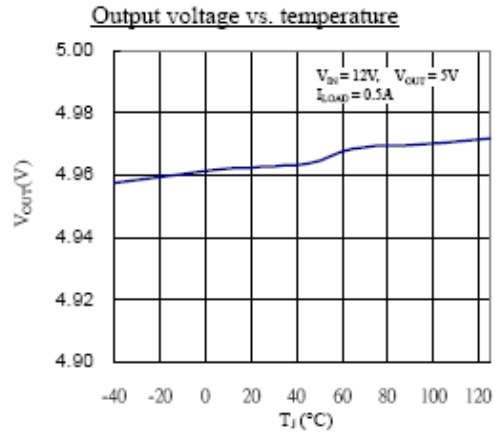
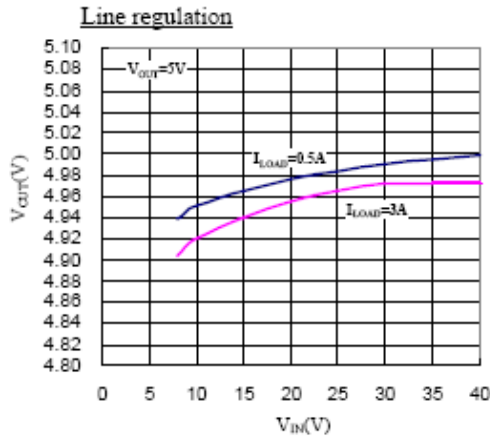

◆ TYPICAL PERFORMANCE CHARACTERISTICS

Test circuits of Figure 1 and 2, $T_j=25^\circ\text{C}$, unless otherwise specified.

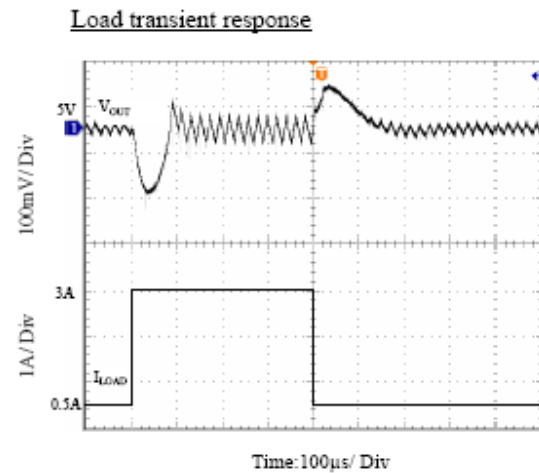
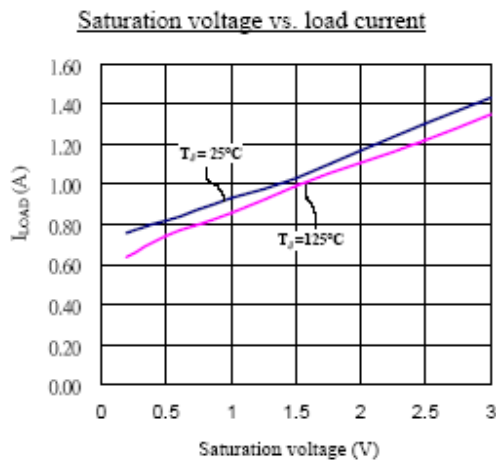

◆ PHYSICAL DIMENSIONS

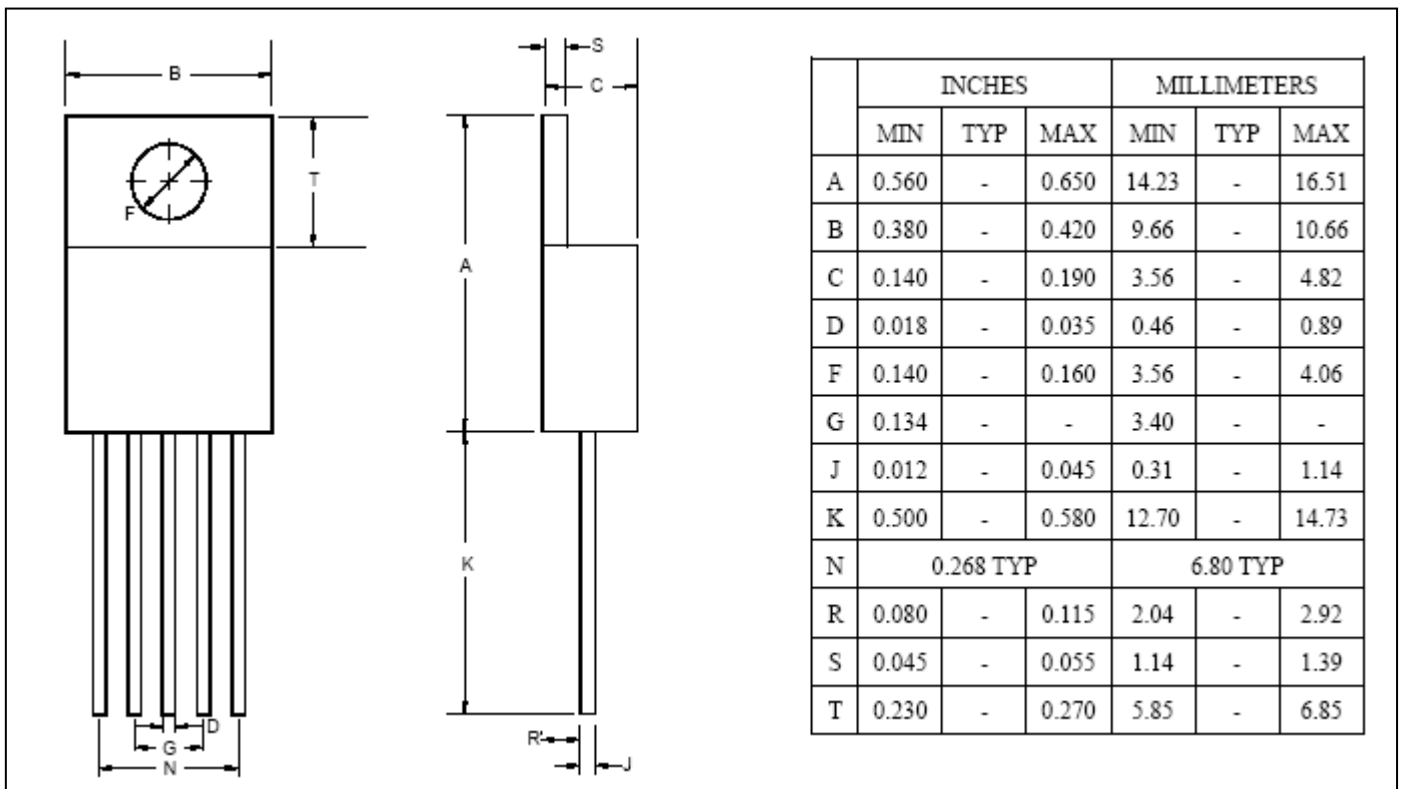
5-Pin Plastic TO-220 (K)

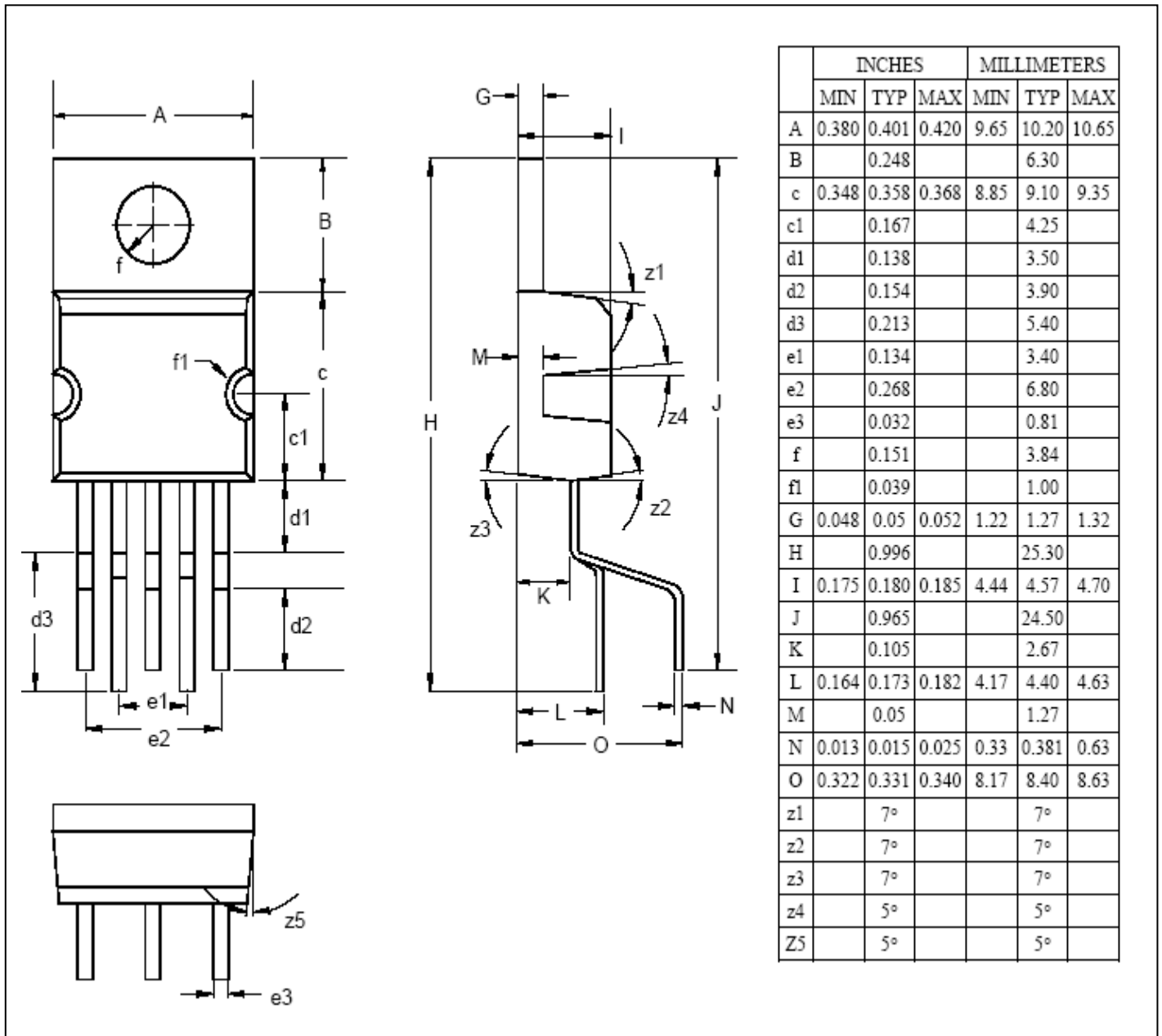

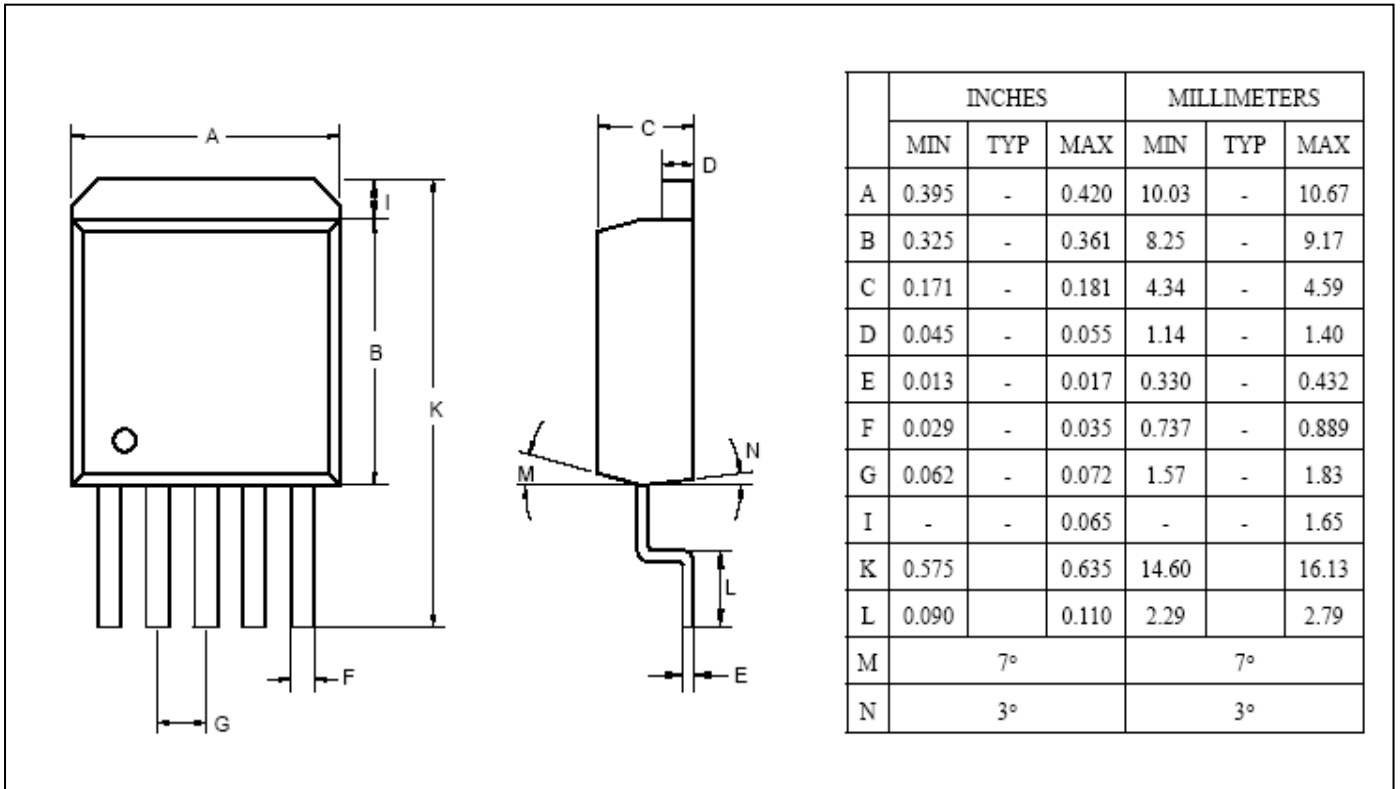
◆ PHYSICAL DIMENSIONS
5-pin TO-220(C)

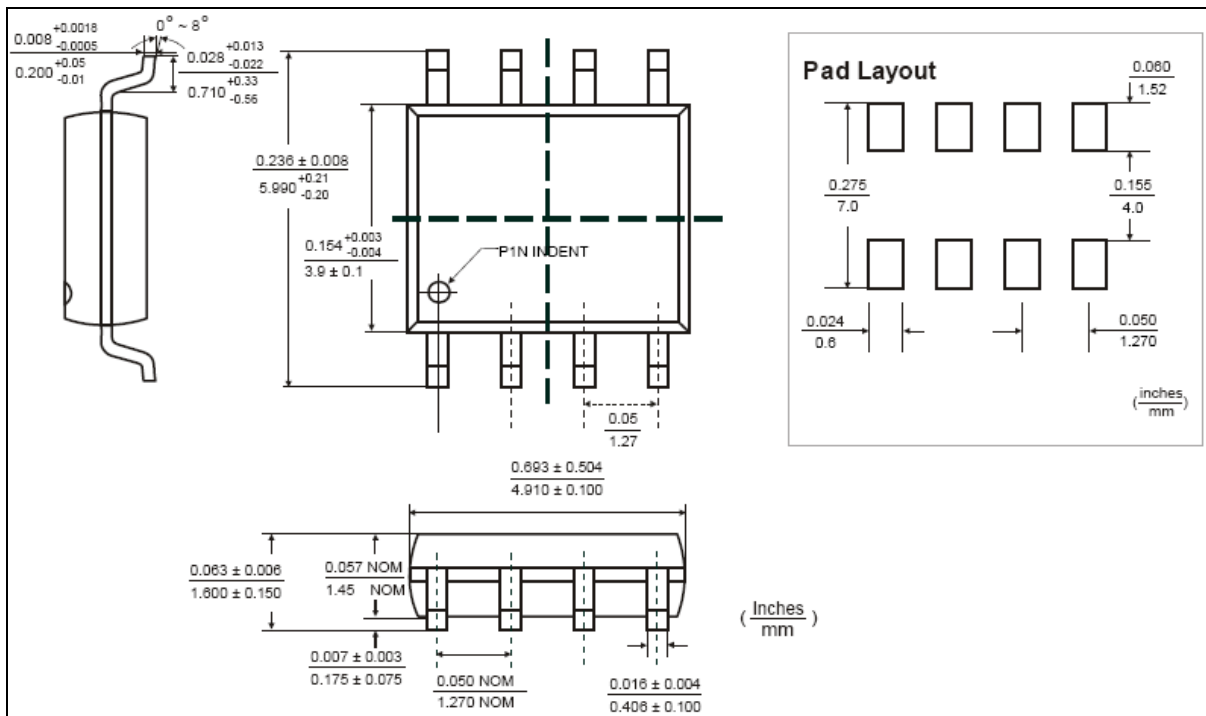
◆ PHYSICAL DIMENSIONS
5-pin TO-263(D)

◆ PHYSICAL DIMENSIONS
8-Pin Plastic S.O.I.C. (M)

◆ PHYSICAL DIMENSIONS
8-Pin Plastic S.O.I.C. (P)
